

# NEOFIX

## NEOFIX® 250

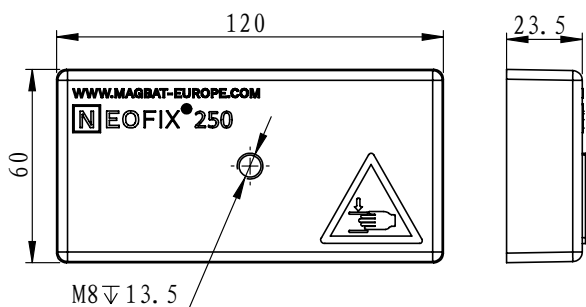

Model:	NEOFIX®250
Pull force:	250 DaN
Shear force:	95 DaN
Material:	NdFeb
Coating:	EPDM
Colour:	RAL 5003 (Blue)
Dimensions:	120*60*23.5 mm
Weight:	1 kg
Thread:	1x M8*13.5
Thread material:	RVS 316 L

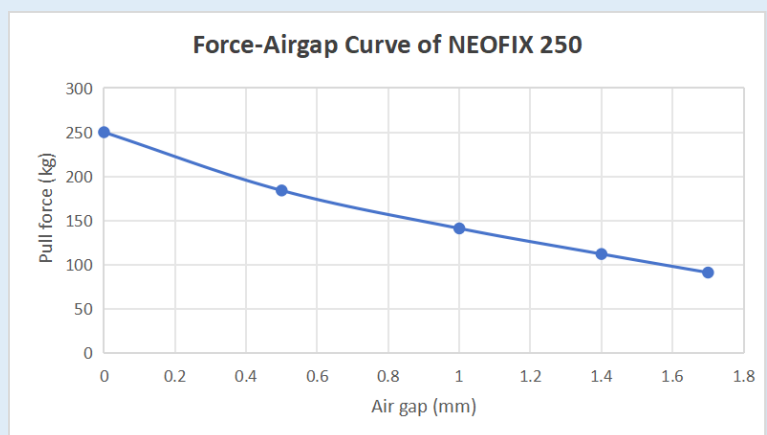

# NEOFIX

## APPLICATIONS



## ASSEMBLY AND DISMANTLING

### ASSEMBLY

- Remove the magnet protection
- Remove impurities and loose parts from the mounting wall / ceiling / floor before attaching the magnets.
- Preferable use the NF-TOOL to attach the magnet.
- NOTE: Never place fingers or other limbs between the magnet and the magnetic surface.

### DISMANTLING

- Screw the NF-TOOL into the magnet
- Tilt the magnet away from the magnetic material

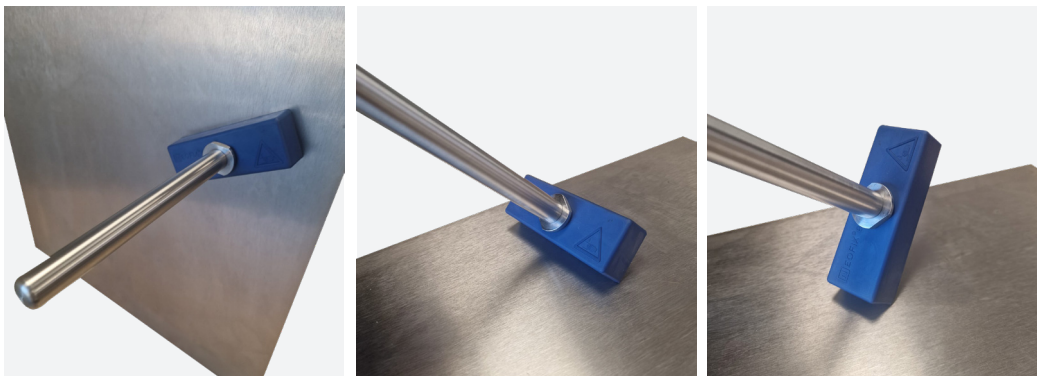

## SAFETY INSTRUCTIONS

- Always read the assembly and dismantling instructions before using the magnets.
- NEOFIX® magnets are very strong. Never place fingers or other limbs between the magnet and magnetic surface. This can result in serious injury!



## STORAGE

- Always place a layer of non-magnetic material between 2 magnets when you store them.