

	S E L E C T	A	←→ Min= 500mm Max=1.300mm	↑↓ Min=500mm Max=1.500mm	Max. 1.500 kg
		B	←→ Min=1.300mm Max=3.000mm	↑↓ Min=500mm Max=2.500mm	Max. 3.000 kg
		C	←→ Min=3.000mm Max=4.500mm	↑↓ Min=500mm Max=3.000mm	Max. 6.000 kg
		D	←→ Min=4.500mm Max=6.000mm	↑↓ Min=500mm Max=3.000mm	Max. 6.000 kg

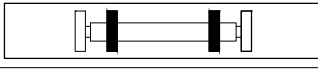
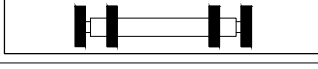
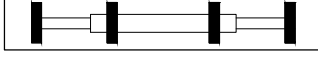
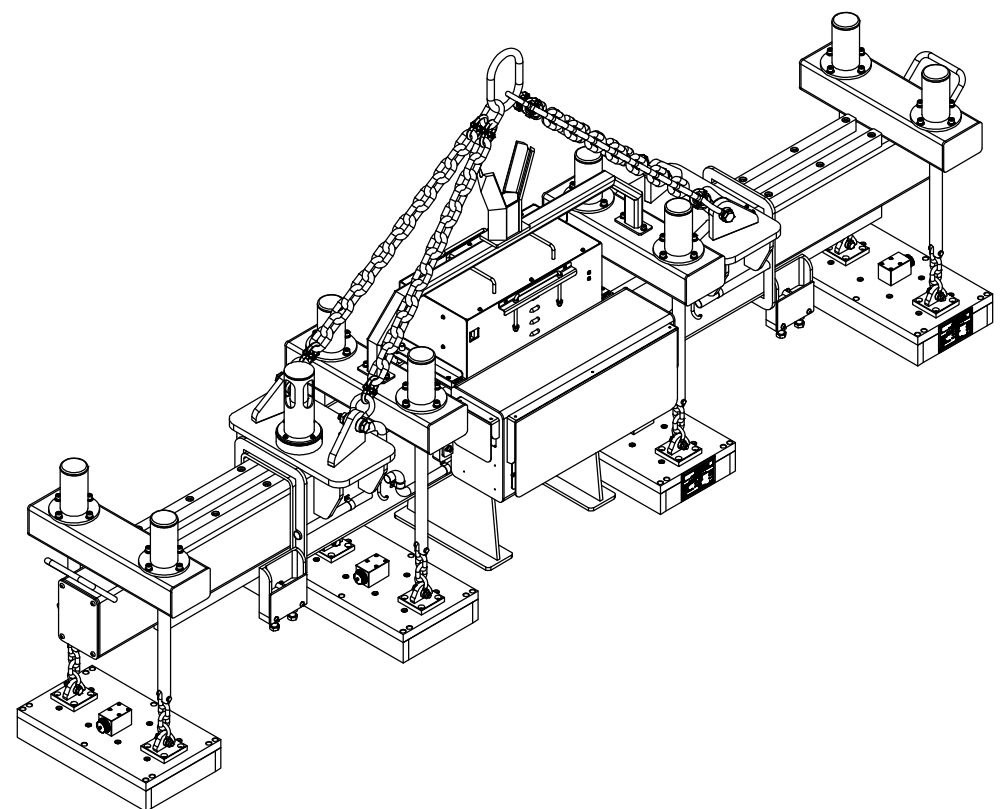
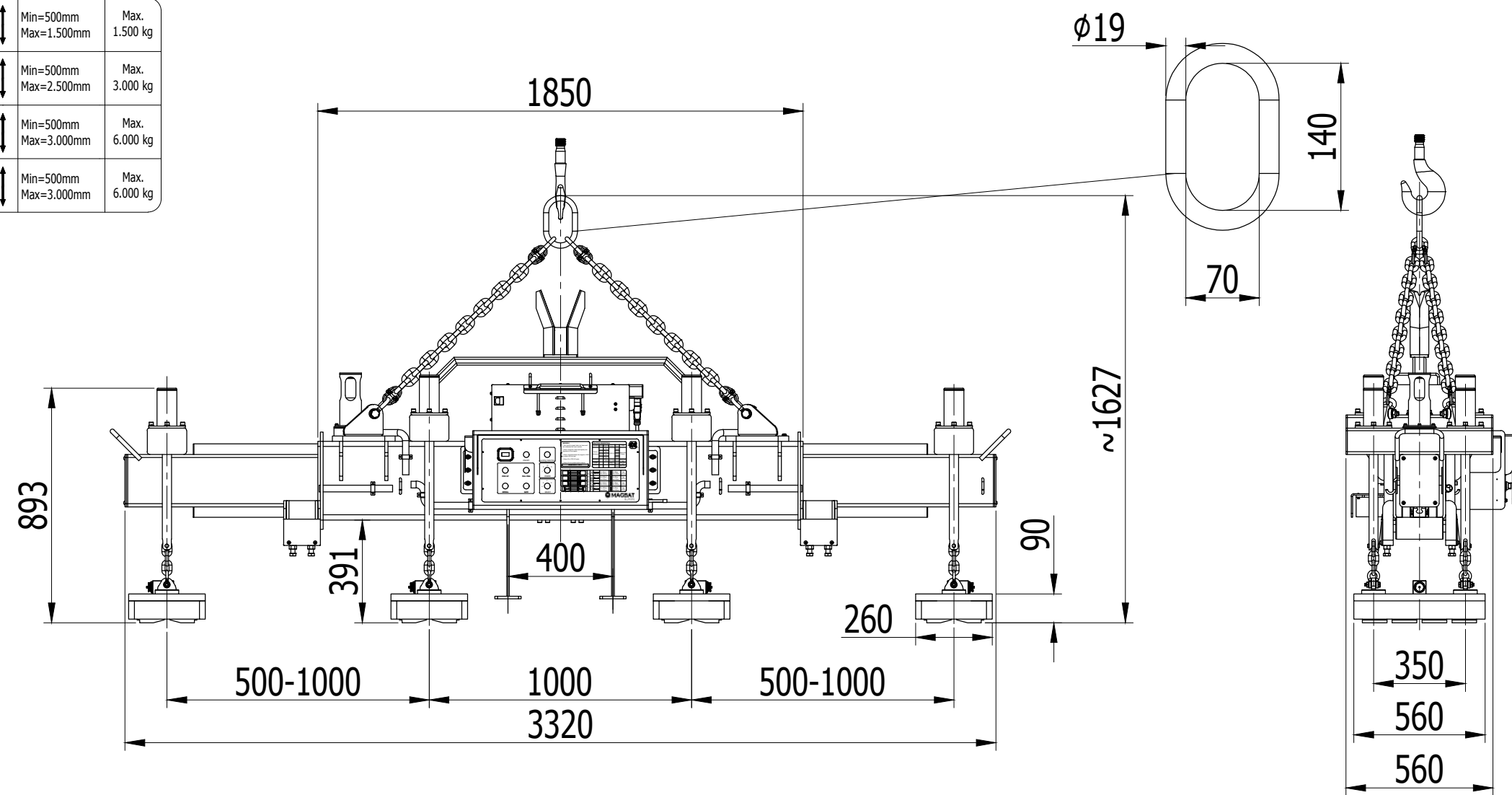

Indicative Weight: 1.030 kg

Indicative drawing. We reserve the right to modify the design at any time

Index	Date	Modification	Name
			Date: 17/06/2020 Drawing: QI Checked: BIN
HBEPP-06-060/T EPM beam for lifting of steel plate			Scale: 1:30 Unit:mm HFA20161.00 Indicative drawing