

	SELECT	A	←→ Min= 500mm Max=1.300mm	↑↓ Min=500mm Max=1.500mm	Max. 500 kg
		B	←→ Min=1.300mm Max=3.000mm	↑↓ Min=500mm Max=2.500mm	Max. 1.000 kg
		C	←→ Min=3000mm Max=4.500mm	↑↓ Min=500mm Max=3.000mm	Max. 2.000 kg
		D	←→ Min=4.500mm Max=6.000mm	↑↓ Min=500mm Max=3.000mm	Max. 2.000 kg

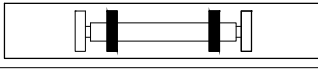
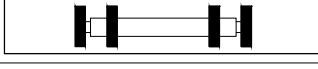
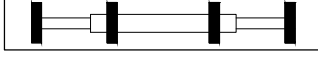
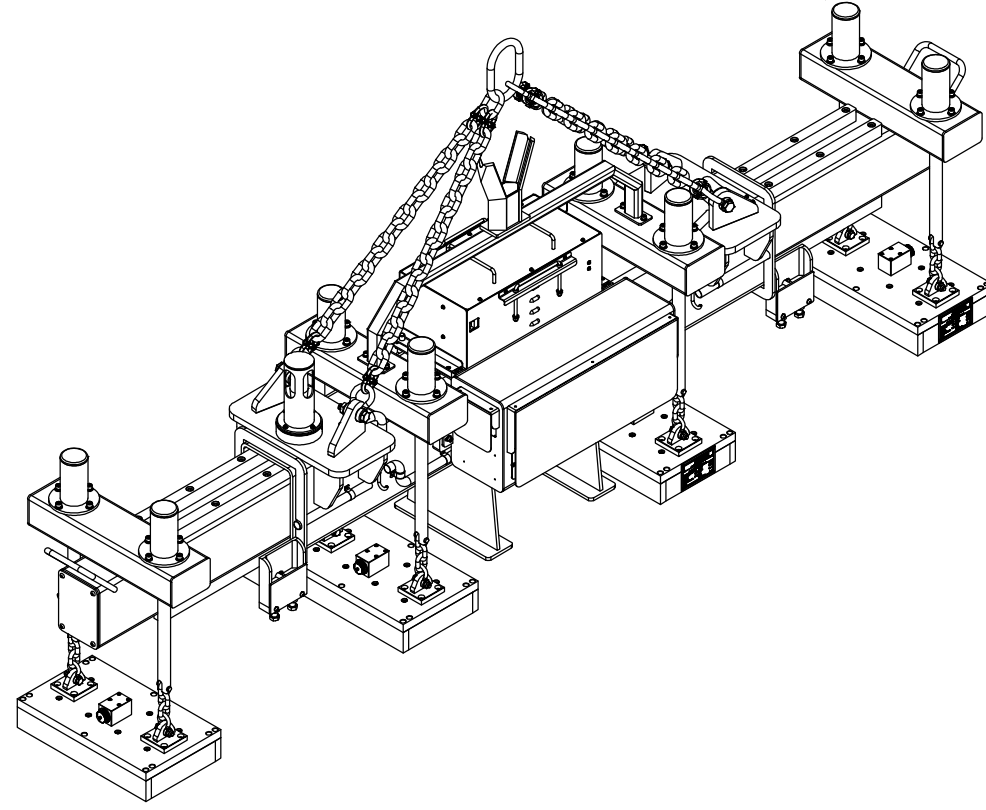
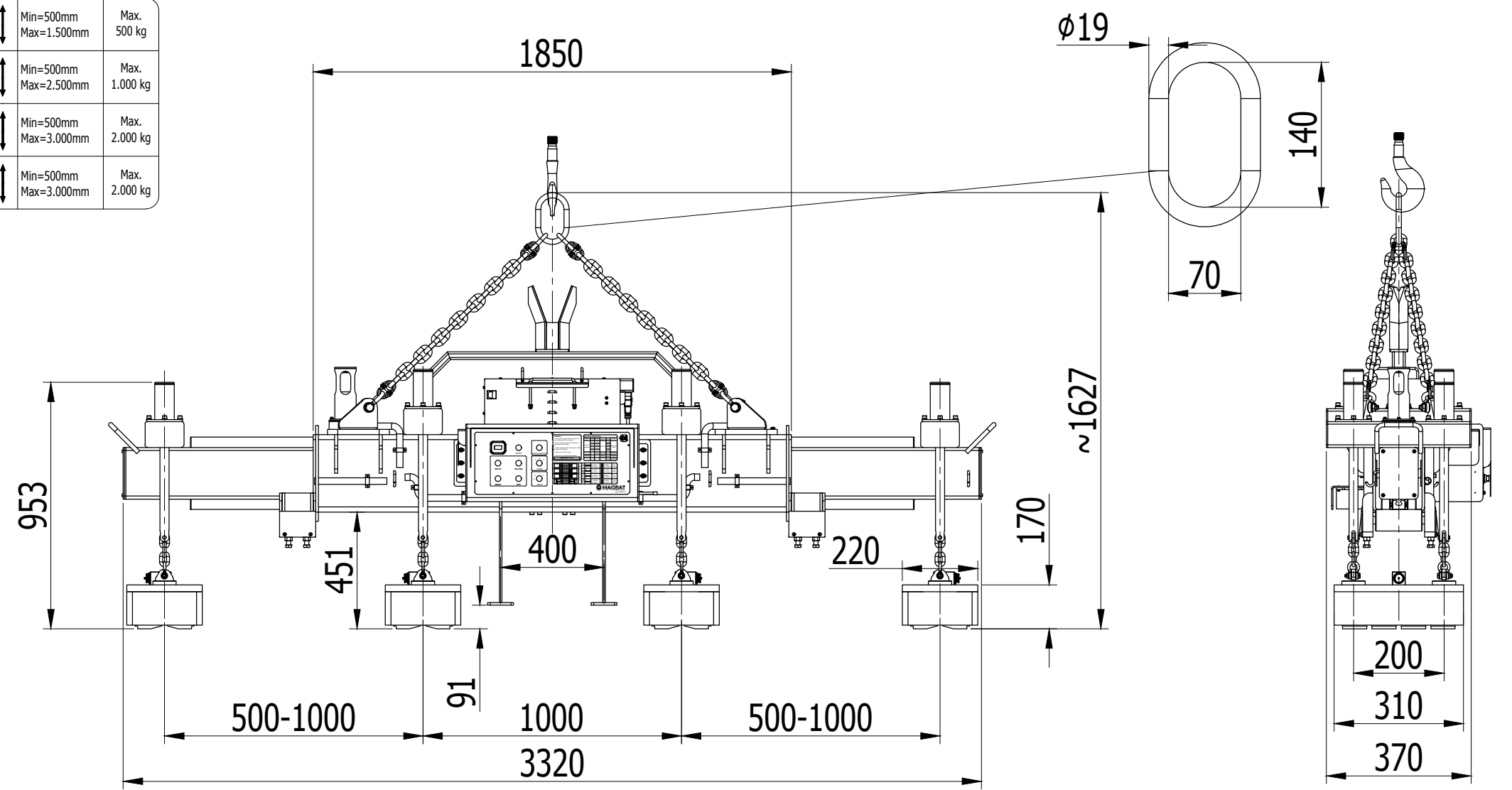

Indicative Weight: 780 kg

Indicative drawing. We reserve the right to modify the design at any time

Index	Date	Modification	Name
			<b>HVR MAG®</b>
 <b>MAGBAT</b> EUROPE			Date: 17/06/2020
			Scale: 1:30
<b>HBEP-06-020/T</b> EPM beam for lifting of steel plate			Checked: BIN
			Unit:mm
			<b>HFA20160.00</b> Indicative drawing